

FIXING INSTRUCTIONS - SNAP ON ASTRAGAL GEORGIAN BAR

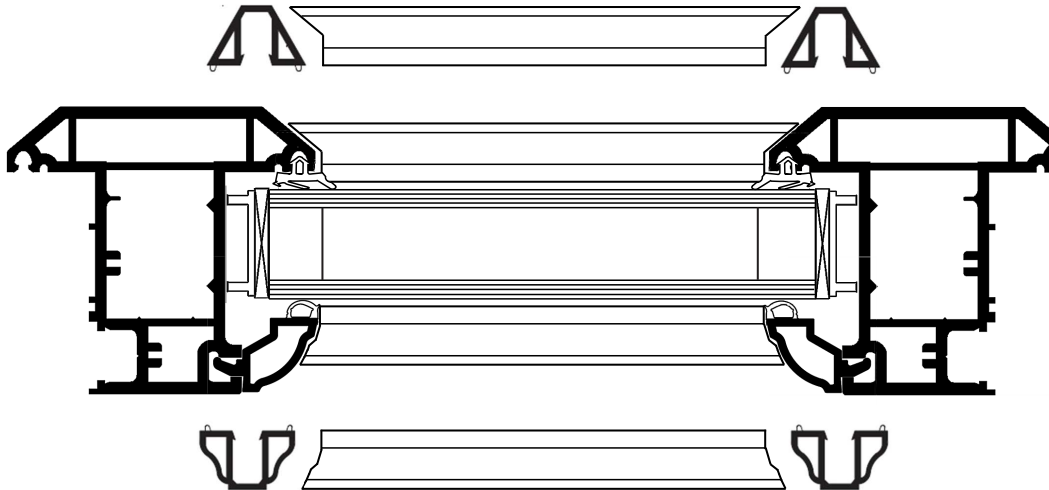

Please be aware that Astragal Georgian Bars are subject to thermal movement in normal site conditions. In order to cater for this movement, please allow for an expansion gap where the bar meets the frame or an adjoining bar in your measurements; this gap should be in excess of 1mm each side.

TYPICAL ASTRAGAL BAR LAYOUT



MEASURING ADVICE FOR CUTTING ASTRAGAL BAR TO RETRO FIT

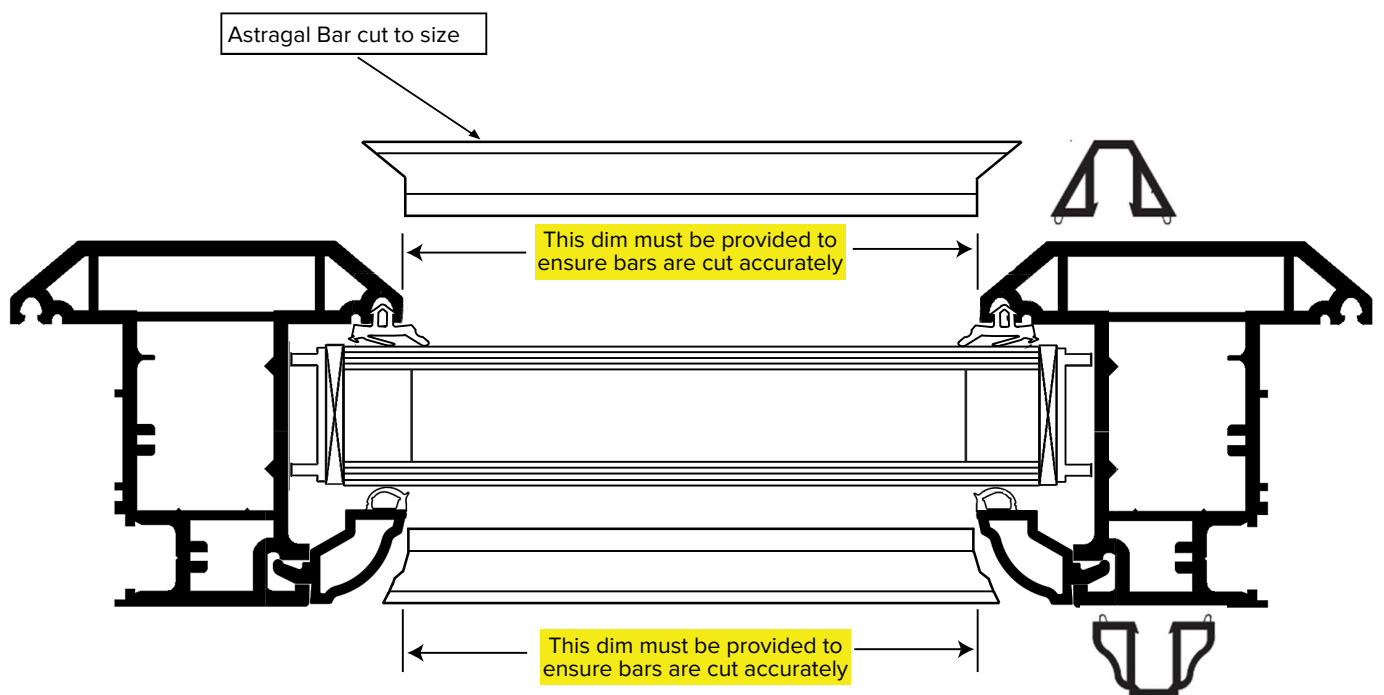

For further assistance, call 01702 613733

www.climatec-windows.co.uk

11-14 Fletchers Square, Temple Farm Industrial Estate, Southend-on-Sea, Essex SS2 5RN

FIXING INSTRUCTIONS - SNAP ON ASTRAGAL GEORGIAN BAR



CUSTOMER: _____ REFERENCE: _____

Please advise if measurements are bar to bar, bar to frame or bar to sash. All bars to be marked individually, for on site installation.

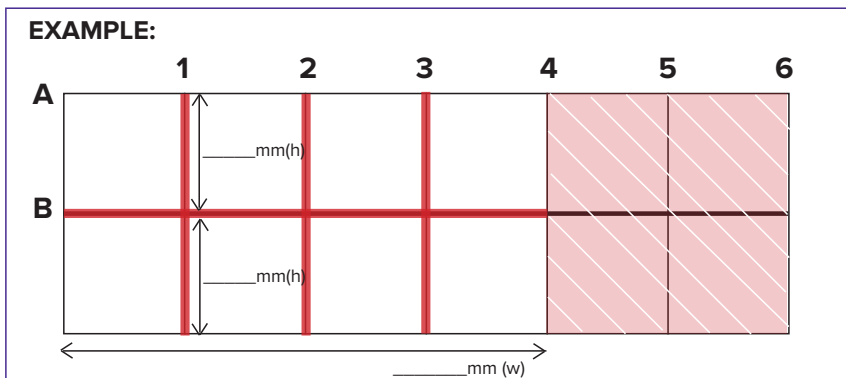
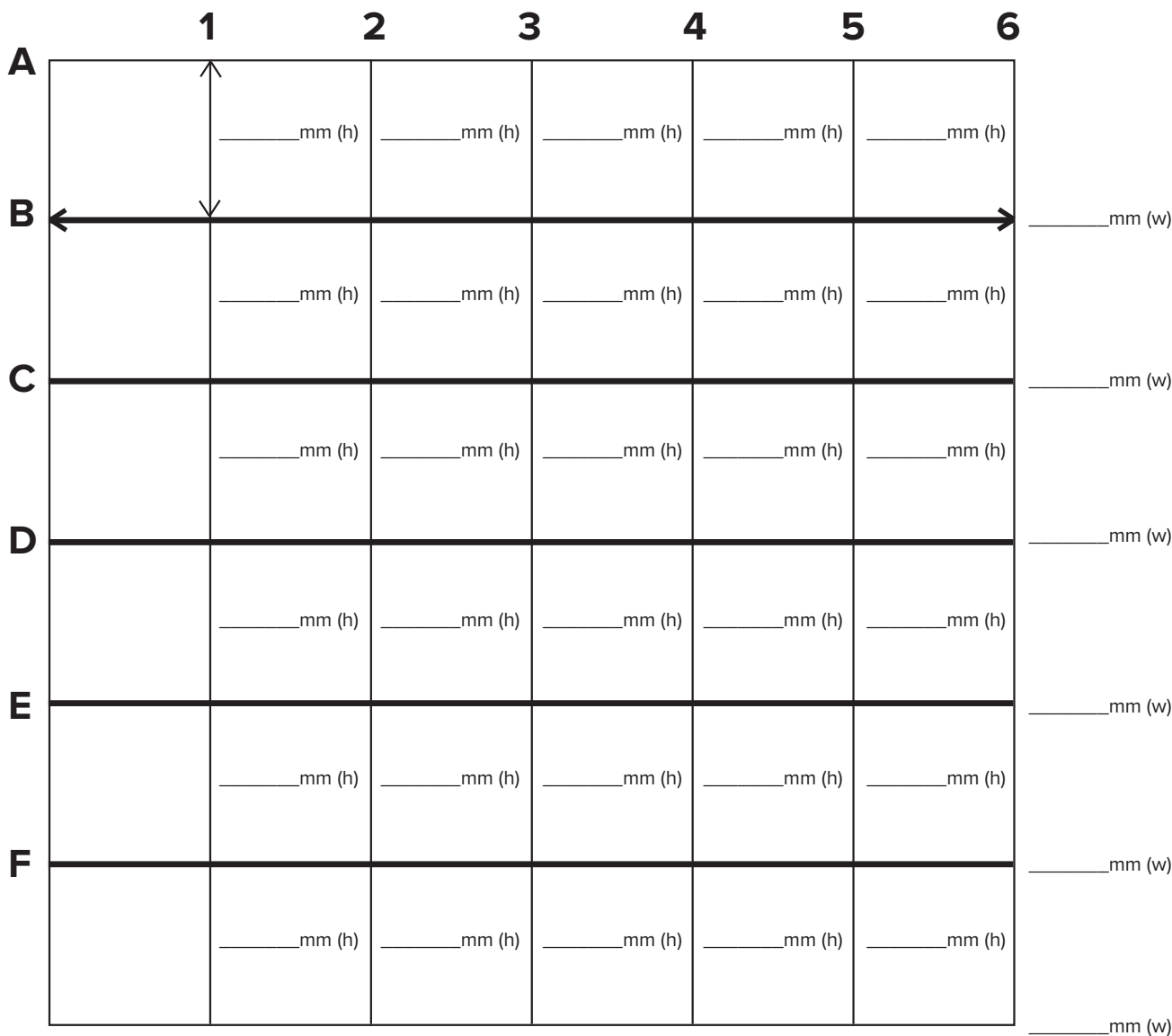

For further assistance, call 01702 613733

www.climatec-windows.co.uk

11-14 Fletchers Square, Temple Farm Industrial Estate, Southend-on-Sea, Essex SS2 5RN

FIXING INSTRUCTIONS - SNAP ON ASTRAGAL GEORGIAN BAR

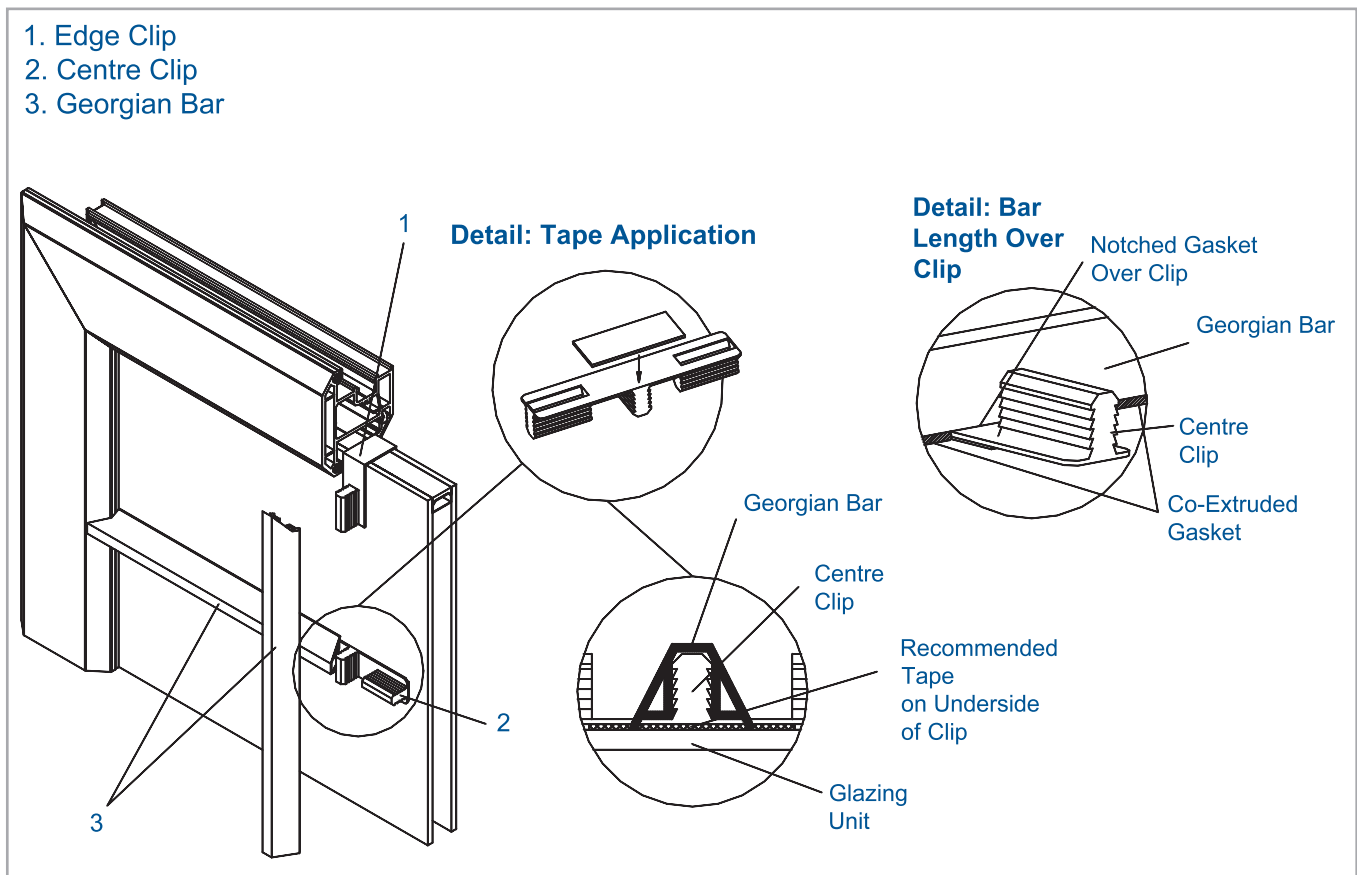

STEP 1

Place edge clips in the required positions around the sealed glazing unit.

STEP 2

Glaze window as per manufacturing and glazing instructions in the applicable Technical Manual. Ensure that clips have retained their position prior to final beading. Adjustment of clip position following final beading should be minimal.

STEP 3

Accurately align the centre clip to the edge clips. Once located the clip can be fixed using a length, approximately 40mm, of double sided tape (See Notes 1 and 2). This should be placed in the centre of the underside of the clip, as shown above. Prior to tape application ensure all surfaces are clean, dry and free of grease.

STEP 4

Precisely cut and mitre the full length bar. This should always be shortest span for increased rigidity. To avoid arching of full-length bars, notch the co-extruded gaskets where the bar crosses the centre clip. This should allow the bar to sit flat against the glass. See Detail: Bar Length Over Clip and Note 3.

STEP 5

Cut and mitre the remaining bars prior to fitting ensure the lengths are cut accurately.

For spans greater than 300mm a single bridging clip and a patch of tape should be used at midpoints to increase rigidity.

Repeat Steps 1-5 for opposite side.

Notes:

1. Adhesive tapes should be applied as per manufacture instructions.
2. Thermal expansion allowance in cutting size should be used: White PVCu allow 1.6mm/m, Coloured/Foiled allow 2.4mm/m. Bar lengths should be processed at minimum 17°C up to standard workshop temperature (assumed 21°C).
3. Storage of system must comply with Technical Delivery Specification from your systems supplier.
4. Care should be taken during any further transportation to ensure bar lengths are suitable for application.

For further assistance, call 01702 613733

www.climatec-windows.co.uk

11-14 Fletchers Square, Temple Farm Industrial Estate, Southend-on-Sea, Essex SS2 5RN