

Slider 24 - Mechanically Jointed Kit Form Outer Frame

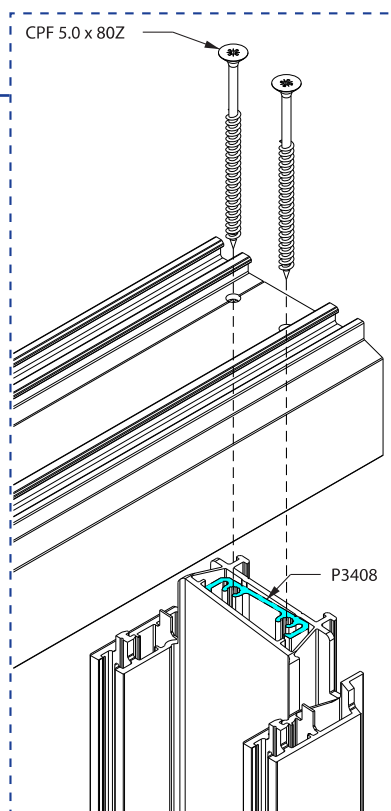
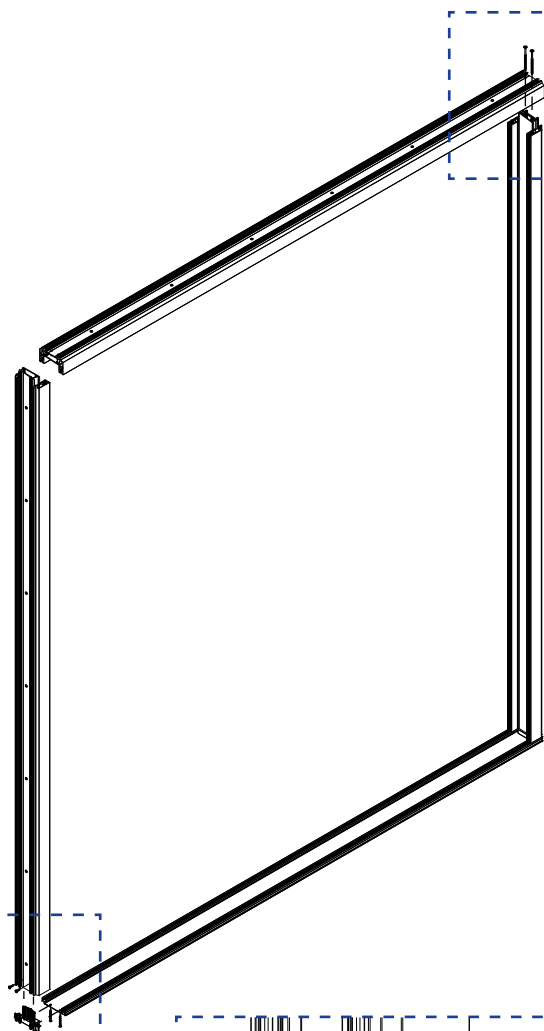

MECHANICALLY JOINTED HEAD P4400 & CILL P4400 TO JAMB P4400 ASSEMBLY

Step 1:

Ensure end milled jambs P4400 are clean and burr free.

Step 2:

Apply silicone sealant to jamb end and align holes to screw port.

Step 3:

Using fasteners CPF 5.0 x 80Z, secure jambs to head and cill.

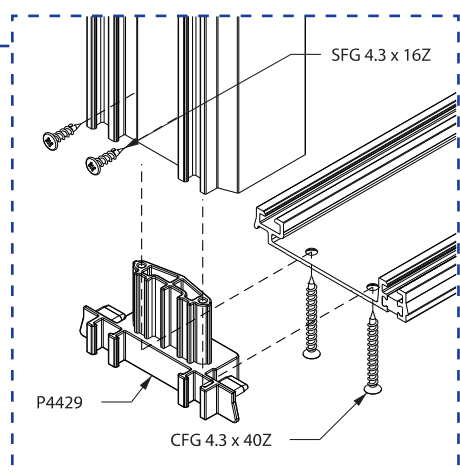

MECHANICALLY JOINTED LOW THRESHOLD CILL P4462 TO JAMB P4400 ASSEMBLY

Step 1:

Ensure sawn jamb ends P4400 are clean and burr free.

Step 2:

Apply silicone sealant to jamb ends and low threshold cill.

Step 3:

Slide mech joint P4429 into jamb and secure using fasteners SFG 4.3 x 16Z.

Step 4:

Slide mech joint P4429 into low threshold and secure using CFG 4.3 x 40Z.

For further assistance, call 01702 613733

www.climatec-windows.co.uk

11-14 Fletchers Square, Temple Farm Industrial Estate, Southend-on-Sea, Essex SS2 5RN